



The Savage XL 5.9 debuts!  
 Enjoy driving the "XL" monster truck with incredible size, power and performance!



Length : 570mm  
 Width : 435mm  
 Wheelbase : 390mm  
 Tyre Diameter : 170mm



Length : 534mm  
 Width : 427mm  
 Wheelbase : 336.5mm  
 Tyre Diameter : 159mm

**BIGGER!**

**LONGER!**



**SAVAGE XL**



**SAVAGE X4.6**

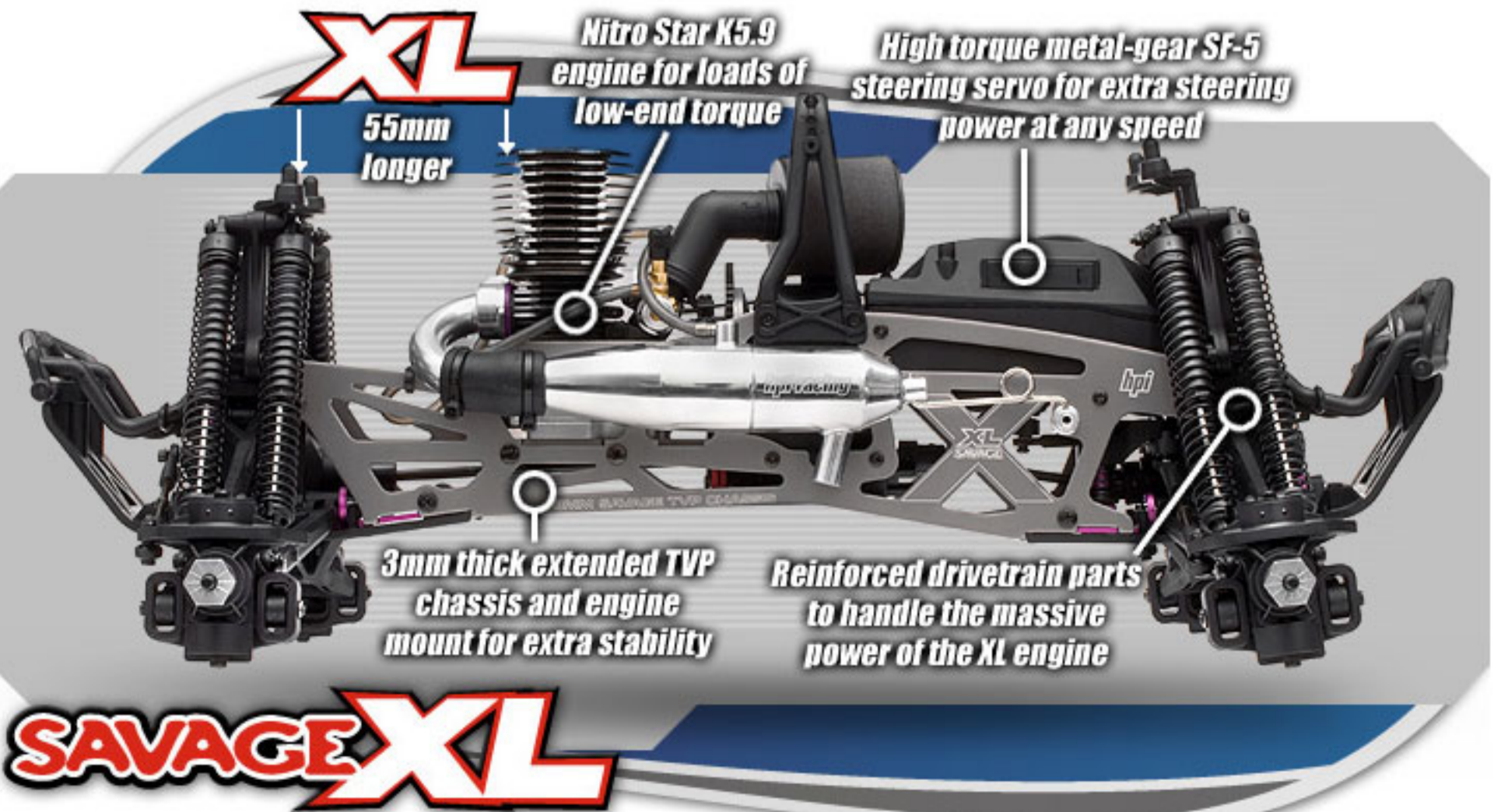

# SAVAGE 5T FEATURES

## Extra-Long Alloy Chassis

To get the long wheelbase of the Savage XL, the HPI designers developed all-new extended TVP (Twin Vertical Plate) chassis made from 3mm thick 6061 aluminum. 6061-series aluminum is light and strong and provides the strength for stretching the Savage platform to its limits! The chassis has Savage XL logos etched into the chassis to really make it stand out! The engine is fitted to a one-piece engine mount with an extra-thick 3mm engine mounting plate. These are the thickest TVP and engine plate parts ever offered on a Savage monster truck, giving the Savage XL the strength to withstand the torque of the massive Nitro Star K5.9 engine.



## Huge Terra Pin All-Terrain Tires

The large Terra Pin tires and TVP style chassis help give the Savage XL massive ground clearance of over 3 inches, allowing it to go over obstacles that would stop other monster trucks in their tracks! The new Terra Pin tires stand tall at nearly 7" in diameter to soak up ruts, bumps, and rough landings. The tough spike pattern makes the Terra Pins great in grass and loose dirt, while the chevron center pattern give them directional stability on the harder surfaces. The tall sidewalls provide extra shock absorption and allow the tires to grip as they roll over obstacles.



## 3 Speed Transmission Installed

The Savage XL features the Savage 3-speed transmission to get the most out of the huge torque from the K5.9 engine. Metal gears with the new high-speed 3rd gear give you legendary durability, consistent shifting, quick acceleration and high top speed. The transmission is fully adjustable, so you can choose when the Savage XL will shift into higher gear!



## Wider Stance & 17mm Hex Hubs

To widen the stance of the Savage XL we added extended aluminum axles with 17mm hex hubs. These are lightweight and tough, and fit standard 17mm hex monster truck and truggy wheels. Serrated steel wheel nuts grip the wheels to keep them locked in place, making sure that you'll never see a wheel bouncing past your truck!



## Reinforced All-Metal Differentials

The Savage XL continues the tradition of tough, overbuilt HPI monster trucks with several new drivetrain parts that are a standard part of the Savage XL's arsenal of tricks. Machined steel diff rings and pinion bevel gears are built to take the power of 5.9cc of nitro-burning mayhem. Alloy diff cases and 4-gear diffs with new larger diff outdrives and axles round out the ultra-strong differentials.



## Thicker Dogbones

New extra-thick dogbones provide the insurance you'll want when you take the XL into rough country! The thicker diameter and larger ends add up to a drivetrain that won't let you down when the going gets tough! You'll be able to commit the full power of the K5.9 engine to the ground!



## Machined Steel Spur Gear

A machined steel 52T spur gear is the perfect match for the horsepower of the Nitro Star K5.9 engine. With a heavy-duty vented clutchbell spinning the spur gear, you get a huge amount of drivetrain protection with gears that won't strip, melt or break in the roughest of terrain and conditions!



## Aluminum Three-Shoe Clutch

The Savage XL uses a new 3-shoe aluminum clutch to get the power from the engine to the drivetrain. The aluminum clutch shoes will resist wear and engine heat for extra life and consistent launches. There's no more secure way to get the power to the ground!



## High Torque Metal Gear Steering Servo

The HPI designers chose a super-strong, extra-tough high torque metal gear servo for the Savage XL. With nearly 9kg of force per centimeter, the SF-5 will get turn the large Terra Pin tires for responsive steering at any speed! There's no need to upgrade the servo - this baby's got it all! With the bellcrank steering and built-in servo saver, you can be sure that the SF-5 will be fully protected against crash damage or bad landings!



## Rechargeable Receiver Pack and Charger

To make sure the servos have all the power they need and then some, we're throwing in an HPI 6 volt 1200mAh NiMH battery pack! This rechargeable pack even includes a convenient wall charger so you can make sure that the XL is always ready to rumble! You don't even need to take the pack out of the truck to charge it - just use the convenient charging jack built into the radio box and you're ready to go!





# K5.9 BIG BLOCK

**3.75 horsepower!**

**6-port design**

**39,500 RPM max**

**Bore: 20.5mm**

**Stroke: 17.5mm**

**14mm SG-type crankshaft**

**ABC construction**

**9.5mm carb opening**

## Tuned Exhaust System

With a curved rear-exhaust manifold directing exhaust gases to the polished aluminum 2-chamber tuned pipe, the specialized K5.9 exhaust system produces loads of horsepower that just demands to be used! The exhaust system is spring-loaded to enable it to withstand the brutal landings of big-air jumps and driving over any type of terrain, and is designed just for the K5.9 engine to produce maximum punch and monstrous top speeds!



## Tough ABC Construction

With true ABC construction (Aluminum case and piston, Brass Chrome-plated cylinder), the Nitro Star K5.9 delivers massive torque and horsepower and long engine life. The three-needle carburetor uses a 9.5mm inlet to get in as much fuel as possible and uses a composite body to prevent heat from the engine case affecting the fuel supply. A huge flow-through finned aluminum heatsink head keeps things cool, and even features sweet laser-etched logos!



## Roto Start 2 Installed

Get things going quickly with the Roto Start 2 electric starting system pre-installed onto the back of the engine. The Roto Start 2 replaces the standard pullstarter with a handheld shaft-drive starting unit so you don't have to deal with pullstarting the engine by hand. Just install a charged 7.2v stick-pack battery into the Roto Start 2 hand unit, insert the shaft into the back of the engine, press the button and you're off! It doesn't get any easier!





Full-time shaft drive 4WD system for maximum grip, power and grunt!



Extra tough slipper clutch for drivetrain security when landing big-air jumps



Massive 160cc fuel tank for long run times and huge amounts of bashing and racing fun.



Easy-access radio box protects the electronics from splashes, dirt and more



Radio box features openings for battery charging plug (included) and #308 illuminated Battery Level Indicator (not included)



Eight long-stroke oil-filled shock absorbers provide confidence over the jumps and on big-air landings



Savage X shock towers for loads of strength and adjustable suspension settings



Double wishbone suspension for amazing handling and performance at any speed



Lightweight suspension arms improve suspension action and give great response in corners and over bumps



Large 17mm metal alloy hex hubs prevent the hex stripping in the wheels under heavy load applications



Hardened 4-gear diff setup can handle the abuse of high-horsepower engines



Alloy differential cases enhance drivetrain reliability and reduce maintenance downtime



Full array of heavy-duty drivetrain components, from clutch to brakes and outdrives to hubs, ensure you have plenty of fun!



Machined steel brake hub and dual red fibreglass brake discs provide secure and fast stopping power



Cam-type servo saver steering arms improve the efficiency and power of the steering servo



Extremely easy access to front and rear differentials - no chassis disassembly required to get to diffs or tranny gears!



Savage X-style vertical transmission case for fast disassembly and simple access to internal gears

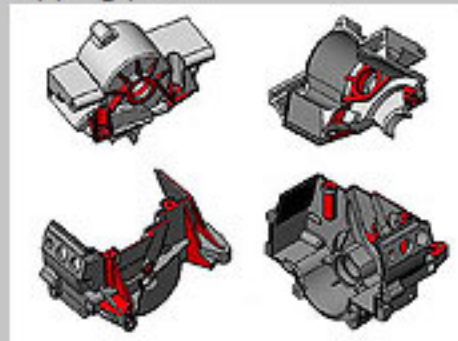

Stronger transmission case with extra webbing and improved strength over earlier Savage designs



Full set of rubber-sealed ball bearings for maximum efficiency and power from the engine.



Bigger, tougher 'GT Gigante' body has classic Savage styling and strength with 0.60" thickness polycarbonate

## SAVAGE XL DIMENSIONS



570mm



435mm

255mm



#10519 -RTR SAVAGE XL 5.9 W/ORANGE GT GIGANTE TRUCK BODY (AUS.)

#10520 -RTR SAVAGE XL 5.9 W/ORANGE GT GIGANTE TRUCK BODY (A SIA)



#10522 -RTR SAVAGE XL 5.9 W/BBLUE GT GIGANTE TRUCK BODY (AUS.)

#10523 -RTR SAVAGE XL 5.9 W/BBLUE GT GIGANTE TRUCK BODY (ASIA)